

# VULCAN III

## Recovery Systems Definition

Students for the Exploration and Development of Space  
University of California San Diego



## Overview

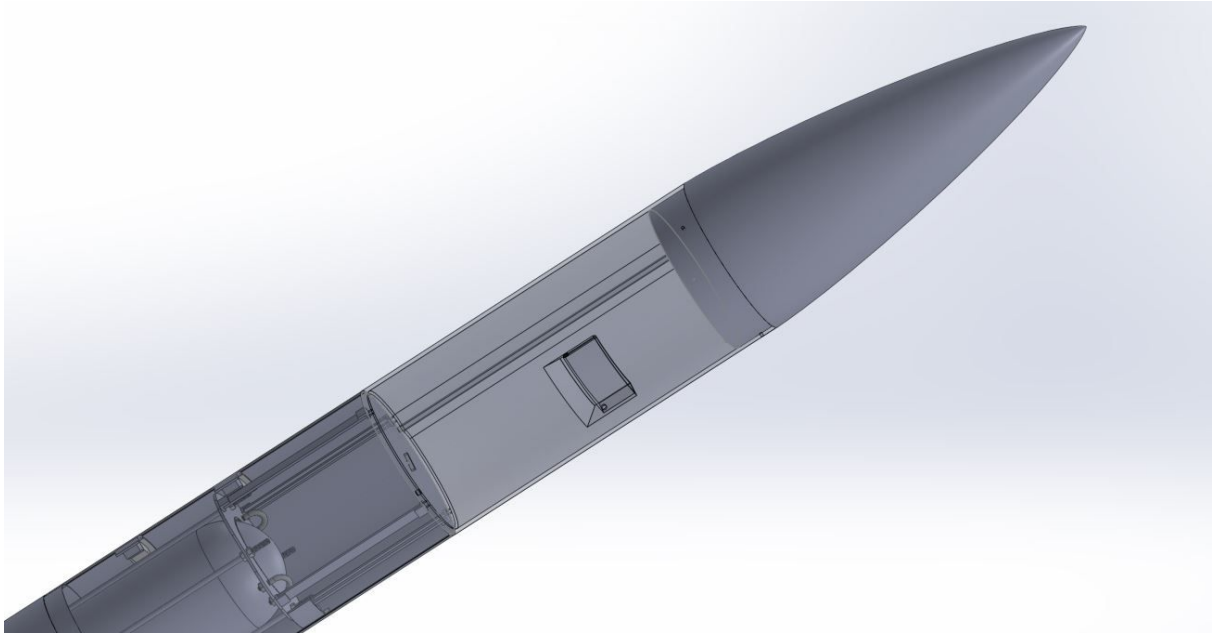

**Figure 1:** location of Recovery Bay with the rocket

The recovery systems for Vulcan-II were designed to meet both competition and basic structural requirements. According to Friends of Amateur Rocketry (FAR) rocketry competition guidelines, a two-stage parachute system must be used. A drogue parachute must be deployed at apogee at approximately 45,000 ft and a primary parachute deployed at an altitude under 1,000 ft. Landing velocity should be no greater than 20 ft/s to preserve the integrity of the payload. Structural requirements aim to keep parachute opening shock below 1500 lbf. Vulcan-II will make use of a linear deployment recovery system in which, in the initial deployment, a black powder charge will detonate and eject the tethered nose-cone and deploy the drogue parachute out of the upper half of the recovery bay. The drogue will be directly connected to the primary parachute that will be held in place within the chamber by a line with a line-cutter charge. At 1,000 ft, avionics will send a signal to detonate the line-cutter, sever the line, and allow the drogue to pull the primary out of the recovery chamber. Velocity at 1,000 ft is estimated to be approximately 80 ft/s thus a parachute opening shock by the primary deployment is expected of 621 lbf to 1,088 lbf, averaging around 870 lbf. The rocket is expected to land with a maximum terminal velocity of 16.76 ft/s.

## Drogue and Primary Chutes



**Figure 2:** Dual deployment parachute system as it nears touchdown.

A 42-inch elliptical parachute was selected as the drogue parachute in the recovery system. This parachute size is small enough to fit in the weight and space specifications desired by our team and minimizes the primary parachute deployment shock by reducing the terminal velocity at 1000 ft (when compared to smaller drogue parachutes). The primary parachute is an Iris parachute supplied by Fruity Chutes Inc. An Iris parachute is a toroidal design that provides one of the highest coefficients of drag in consumer parachutes and thus allows us to use a far smaller size to reach our landing velocity goal of under 20 ft/s. While a standard elliptical parachute would need to be approximately 30 ft in diameter to slow the rocket to under 20 ft/s at landing, the Iris parachute is capable of reaching that goal at a diameter of 16 ft, or 192-inches. Spectra microlines, instead of Nylon lines, were selected for the parachute harness to reduce volume and mass and for superior strength and durability when used with gunpowder charges. An example of the selected parachutes are depicted in Fig. 2 in a linear deployment similar to our own.

## Deployment Charge

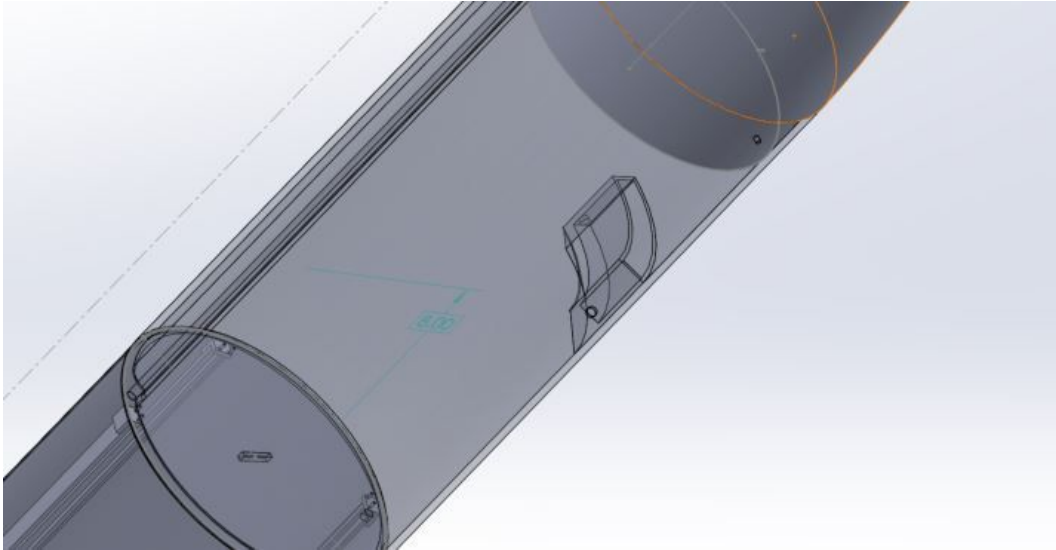

**Figure 3:** the charge is being held in a small chamber within the recovery bay.

A black powder charge of approximately 3-4 grams will be placed within the chamber integrated within the side of the recovery bay (displayed in Fig. 3). This charge will produce 15-20 psi when detonated within the chamber which will be sufficient to shear the nylon shear pins (105 lbs to shear all three) and eject the tethered nose-cone away from the drogue (approximately 680 lbs exerted against the bottom of the nose-cone). The nose-cone will be tethered to the rocket with a kevlar line that runs down a small tube against the inner wall of the recovery bay and through the avionics bay to one of the structural mounting brackets used to support the parachute harness. The location of the charge was determined based on the desire to place it under the drogue. This was to ensure that the drogue would deploy both quickly and reliably. Placement on the side of the vessel was so that no catching would occur. Two Firewire Initiator e-matches, one per redundancy in the avionics systems, independent of each other will be connected to the black powder charge so either can ignite the charge and deploy the drogue parachute.

## Tender Descender Line Cutter and Harness

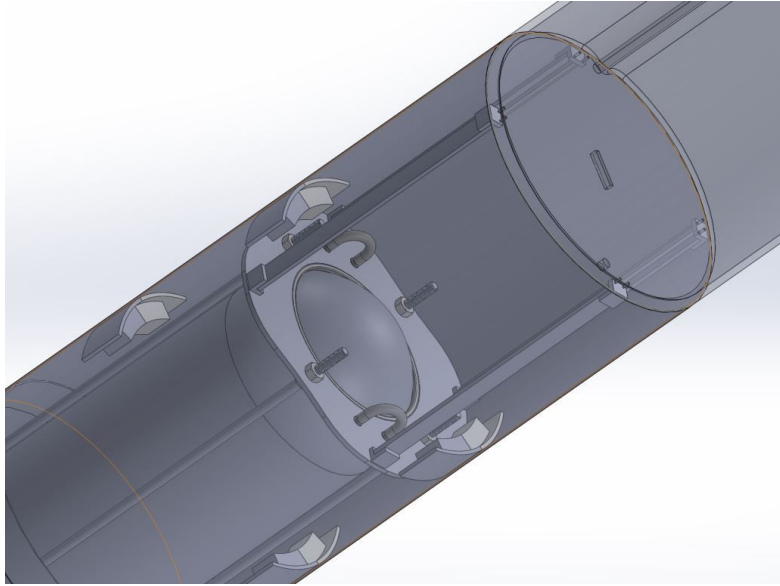

**Figure 4:** Shackles on the top of the end-cap is where the lines are mounted to



**Figure 5:** Quick release in the form of the tender Descender

The harness system will be connected to two brackets mounted directly to the helium tank (Fig. 4). The harness will be a standard Y configuration meeting in the middle with an inch of slack above the middle of the tank. At that point a single nylon shock line rated for 4,000 lbf will rise up through the rectangular hole at the bottom of the recovery bay. This hole (and all others on the bottom of the recovery bay) will be gasketed in order to prevent the pressurization of the avionics bay during the deployment of the drogue when the black powder is detonated. The harness will then connect to two Tender Descender black powder line-cutters (Fig. 5) in series which will each be connected to separate redundant avionics packages (either can independently detonate a line-cutter). The harness will also be connected to the primary parachute so that, when the lines holding the primary parachute in the chamber are cut, the harness will then support the primary parachute's connection to the main rocket body.

## Nylon Shear Pins

Three Nylon 4/40 threaded shear pins, spaced 120 degrees apart along the upper lip of the recovery bay where the cone is male friction fitted to the inside, will be used to hold the nose-cone of the rocket to the recovery bay. The recovery bay will be slightly vented to reduce the force of the pressure differential at 45,000 ft which will reduce the force on the shear pins and reduce the possibility of shearing early. By using three shear pins we can be confident that the nose-cone will not become canted during flight (causing loss of stabilization) and will not come off after acceleration is complete but before apogee is reached. The shear pins will shear at 35 lbf for a total of 105 lbf for the three.